

XP19 Heat Pump ♦ Up to 18.6 SEER and 9.35 HSPF



LENNOX  
INNOVATION NEVER FELT SO GOOD.™

DAVE LENNOX  
*signature*  
COLLECTION

Home Comfort Systems



### **XP19**

The most quiet and efficient heat pump you can buy\*

Enhanced with innovative, new features for improved comfort and energy efficiency

# Dave Lennox *Signature*™ Collection XP19 Heat Pump

Innovation never felt so good.™

Patented SilentComfort™ technology for quiet cooling and heating

Two-stage operation for optimal performance and efficiency

Outstanding efficiency can save you hundreds of dollars each year

Ozone-responsible R410A refrigerant meets the EPA's (Environmental Protection Agency) most stringent environmental guidelines

Lennox® System Operations Monitor reviews system performance for additional peace of mind and faster, easier service

ENERGY STAR®-qualified

SmartHinge™ louvered access panels for improved coil protection and fast, efficient servicing

Want high efficiency, without the cost of high utility bills? The XP19 heat pump more than delivers. Now offering an even greater level of comfort and efficiency, the XP19 takes comfort technology to new heights, so your utility bills reach new lows.

## THE MOST QUIET AND EFFICIENT HEAT PUMP YOU CAN BUY.\*

Enhanced with innovative new features, the XP19 provides ultrahigh-efficiency cooling and heating with two stages of operation. It runs at low stage 80% of the time to reduce energy costs and sound levels. Two-stage operation and exclusive SilentComfort™ technology provide optimal performance for efficient, quiet heating and cooling.

## Efficient Can save hundreds of dollars each year on utility bills

With industry-leading efficiencies of up to 18.6 SEER and 9.35 HSPF, the XP19 is the most efficient heat pump on the market today.\*\*

Nearly twice as efficient as a typical\*\*\* heat pump, the XP19 can lower your utility bills.

### EFFICIENCY RATING

Up to **18.6 SEER** (Seasonal Energy Efficiency Ratio) and **9.35 HSPF** (Heating Season Performance Factor).

### WARRANTY

10-year limited warranty on the compressor.

5-year limited warranty on all remaining covered components.

### 3-YEAR COOLING SAVINGS

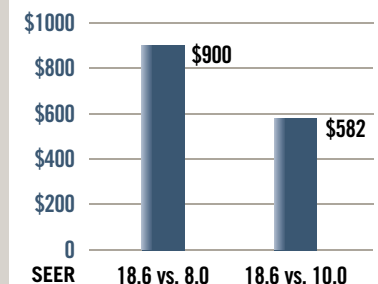

18.6 SEER XP19 Heat Pump, compared to older, less efficient units

This chart compares the 3-year savings you can expect from an XP19 heat pump, vs. units with lower efficiency ratings. Your actual savings will vary depending on the weather, local fuel rates, indoor coil, and your lifestyle. Source: U.S. Department of Energy national average energy rates.

\*A combination of sound ratings established per ARI's test standard: 270 and efficiency ratings established per ARI's test standard: ANSI/ARI 210/240-94.

\*\*Air source heat pumps as rated for ARI's test standard: ANSI/ARI 210/240-94.

\*\*\*10 SEER heat pump

## Quiet **So quiet, you won't believe your ears**

The XP19 is engineered with exclusive SilentComfort™ technology for quiet performance. A patent-pending fan design, two-stage operation and an insulated compressor compartment also keep sound at a minimum.

## Responsible **Conserves energy, while preserving the environment**

The Copeland Scroll Ultra Tech™ compressor uses the new R410A refrigerant, which meets the EPA's standards for ozone and environmental safety.



## Reliable **Features the exclusive Lennox® System Operations Monitor**

Similar to the diagnostics system used in automobiles, this monitor continually measures system performance, helping technicians solve problems faster and more accurately. It can even communicate with select thermostats to provide you with a "Check System" type indicator when service is needed for added peace of mind.



### SOUND INTENSITY



### SUPERIOR MOISTURE CONTROL



## Customizable

**Can be paired with a SignatureStat™ Home Comfort Control for even greater efficiency and comfort**

The SignatureStat™ control combines the functions of a humidistat and thermostat into a single device. Simple, menu-driven programming helps you control your energy costs and comfort.



## Leading the way in comfort and energy efficiency

For the third consecutive year, the EPA has selected Lennox as an ENERGY STAR® Manufacturing Partner of the Year for Lennox' ongoing commitment to producing high-efficiency products and features. Lennox is the only



HVAC (heating, ventilation, and air conditioning) manufacturer ever to be chosen for this annual award.

## CONTINUOUS COMFORT NETWORK

The industry's first integrated home comfort solution

**The XP19 Heat Pump** is designed to easily integrate with other quality Lennox® products for complete, continuous comfort.

**G61V Variable Speed Furnace** is the quietest furnace you can buy.†

**PureAir™ Air Purification System** cleans the air in your home better than any other single system you can buy.

**SignatureStat™ Home Comfort Control** combines the functions of a humidistat and thermostat into a single device.

**Harmony III™ Zoning System** provides customized, room-to-room comfort.

### Dave Lennox Signature™ Collection XP19 Specifications

XP19	024	036	048	060
SEER	Up to 18.50	Up to 18.60	Up to 17.40	Up to 17.00
HSPF IV	Up to 9.10	Up to 9.30	Up to 9.10	Up to 8.75
Sound Rating – Db	69	73	73	73
Dimensions	HxWxD (in.)	37 x 35-1/2 x 39-1/2	37 x 35-1/2 x 39-1/2	47 x 35-1/2 x 39-1/2
	HxWxD (mm)	940 x 902 x 1003	940 x 902 x 1003	1194 x 902 x 1003

*Note: Due to Lennox' ongoing commitment to quality, all specifications, ratings and dimensions are subject to change without notice. Warranties noted apply to residential applications only and are limited. Please see actual warranty for details.*

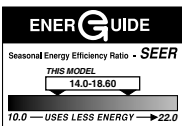

Many Lennox® home comfort systems meet ENERGY STAR® requirements when used with appropriate components. Ask your dealer for details.



Certification applies only when used with proper components as listed with ARI

†Based on sound pressure levels during steady-state, high-fire operation of Lennox G61MPV-36B-070 and leading competitive units at midpoint temperature rise and minimum external static pressure when set up per Section 4.5.3 of ARI 260.

## OUTSTANDING FEATURES FOR EXCEPTIONAL COMFORT AND EFFICIENCY

### SilentComfort™ Fan Grille –

Uses patent-pending, vortex-suppression technology to reduce sound of airflow exiting unit.

### Factory Installed Lennox® System Operations Monitor –

Continually reviews system performance to allow fast troubleshooting.

### Precision-Balanced, Direct-Drive Fan –

Ensures quiet operation.

### Insulated Compressor Compartment –

Minimizes operating sounds with innovative materials and industry-leading, vibration-isolating mounts.

### Copeland Scroll Ultra Tech™ Two-Stage Compressor –

Operates at low stage most of the time for quieter, more efficient performance. Plus, it cools your home using the ozone-responsible R410A refrigerant.

### High-Efficiency Outdoor Coil –

Provides exceptional heat transfer and low air resistance for high-efficiency operation.

### SmartHinge™ Louvered Coil Protection –

Allows quick, easy access to interior components from all sides, so the unit can be serviced in minimal time.

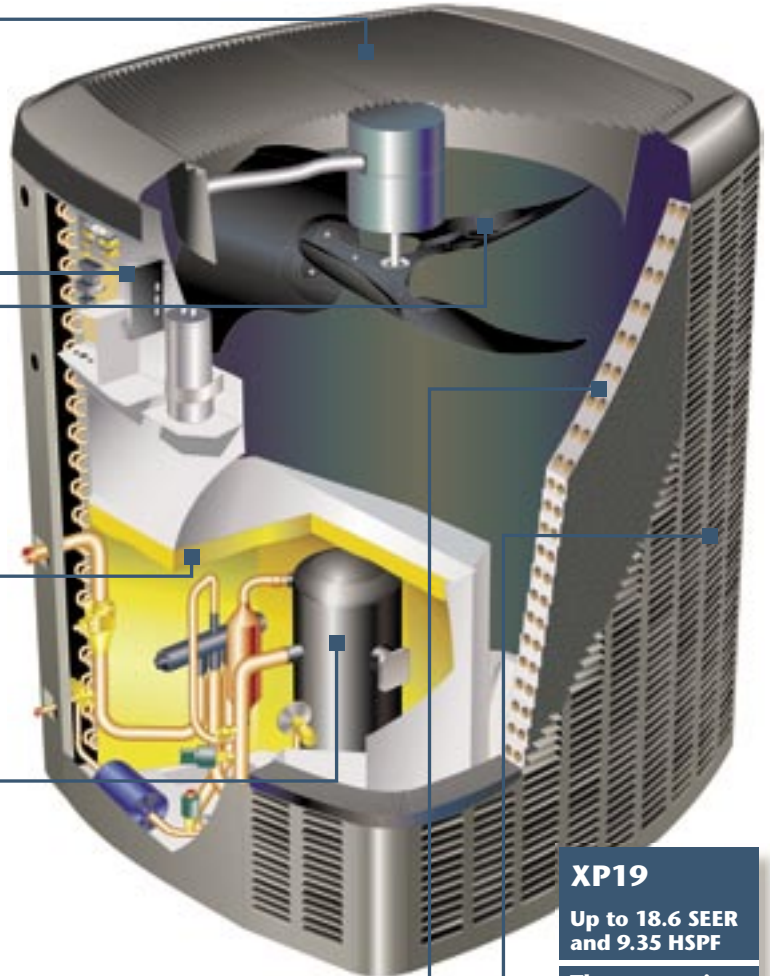

### XP19

Up to 18.6 SEER  
and 9.35 HSPF

The most quiet  
and efficient  
heat pump  
you can buy.\*



\*A combination of sound ratings established per ARI's test standard: 270 and efficiency ratings established per ARI's test standard: ANSI/ARI 210/240-94.



- 1 Air conditioner or heat pump
- 2 Thermostat
- 3 Furnace or air handler
- 4 Filtration device
- 5 Germicidal light
- 6 Indoor coil
- 7 Humidifier
- 8 HEPA bypass filtration system
- 9 Energy recovery ventilator
- 10 Supply duct
- 11 Return duct

## CONTINUOUS COMFORT NETWORK

Lennox® heating, cooling and indoor air quality products are designed to provide efficient, economical comfort—not only as individual units, but also together as an integrated system. This combined network of products delivers on every comfort count, from consistent temperatures and balanced humidity to improved indoor air quality.

## DEALERS YOU CAN COUNT ON

Choosing the right dealer for your heating, cooling and indoor air quality needs is every bit as important as choosing the right brand. We think you'll agree our dealers are a big reason you can count on quality customer service when you call.



**LENNOX**

HOME COMFORT SYSTEMS  
*Innovation never felt so good.™*

© Lennox Industries Inc. 2005

Visit us at [www.lennox.com](http://www.lennox.com), or contact us at 1-800-9-LENNOX.